



Aviat Networks Investor Presentation

Fiscal Q3 2024

Oppenheimer 27th Annual Technology, Internet &
Communications Conference

August 12, 2024

Forward-Looking Statements

The information contained in this presentation includes forward-looking statements within the meaning of the Private Securities Litigation Reform Act of 1995, Section 21E of the Securities Exchange Act and Section 27A of the Securities Act, including expectations regarding our results for the fiscal year 2024. All statements, trend analyses and other information contained herein about the markets for the services and products of Aviat Networks, Inc. and trends in revenue, as well as other statements identified by the use of forward-looking terminology, including "anticipate," "believe," "plan," "estimate," "expect," "goal," "will," "see," "continue," "delivering," "view," and "intend," or the negative of these terms or other similar expressions, constitute forward-looking statements. These forward-looking statements are based on estimates reflecting the current beliefs of the senior management of Aviat Networks, Inc. These forward-looking statements involve a number of risks and uncertainties that could cause actual results to differ materially from those suggested by the forward-looking statements.

For more information regarding the risks and uncertainties for our business, see "Risk Factors" in our most recent Form 10-K filed with the U.S. Securities and Exchange Commission ("SEC"), as well as other reports filed by Aviat Networks, Inc. with the SEC from time to time. Aviat Networks, Inc. undertakes no obligation to update publicly any forward-looking statement for any reason, except as required by law, even as new information becomes available or other events occur in the future.

Company Overview

Aviat Networks is the leading wireless transport and access solutions provider

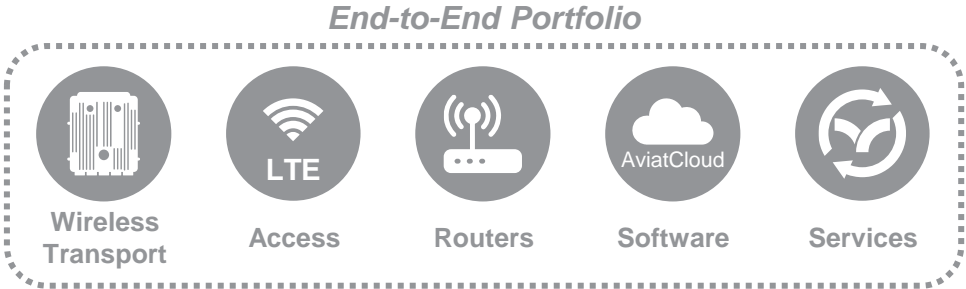

NASDAQ Listed: AVNW

Headquartered in Austin, TX

3,000+ Customers Worldwide

Global Manufacturing Capabilities

Leading Technologies – 200+ Patents

Revenue Summary

LTM Revenue: \$385 Million

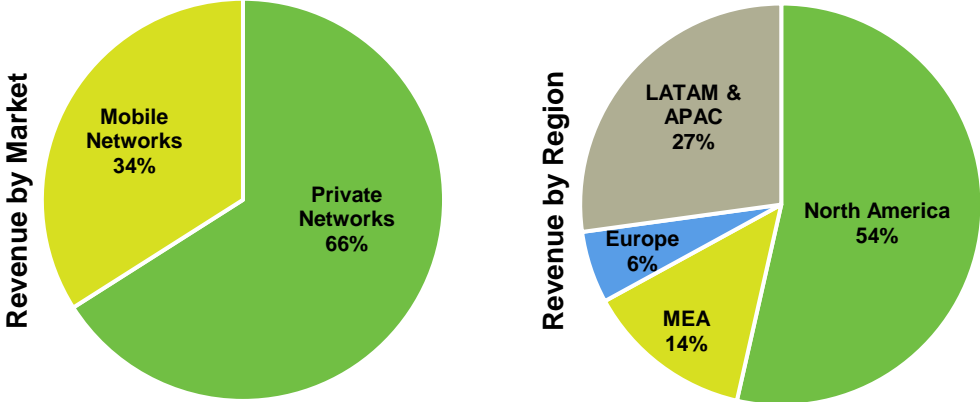

Points of Excellence

- Lowest Total Cost of Ownership
- Mission Critical Solutions Leader
- Unrivalled Microwave Expertise
- Innovative Products and Services

Over 75 Years of Expertise

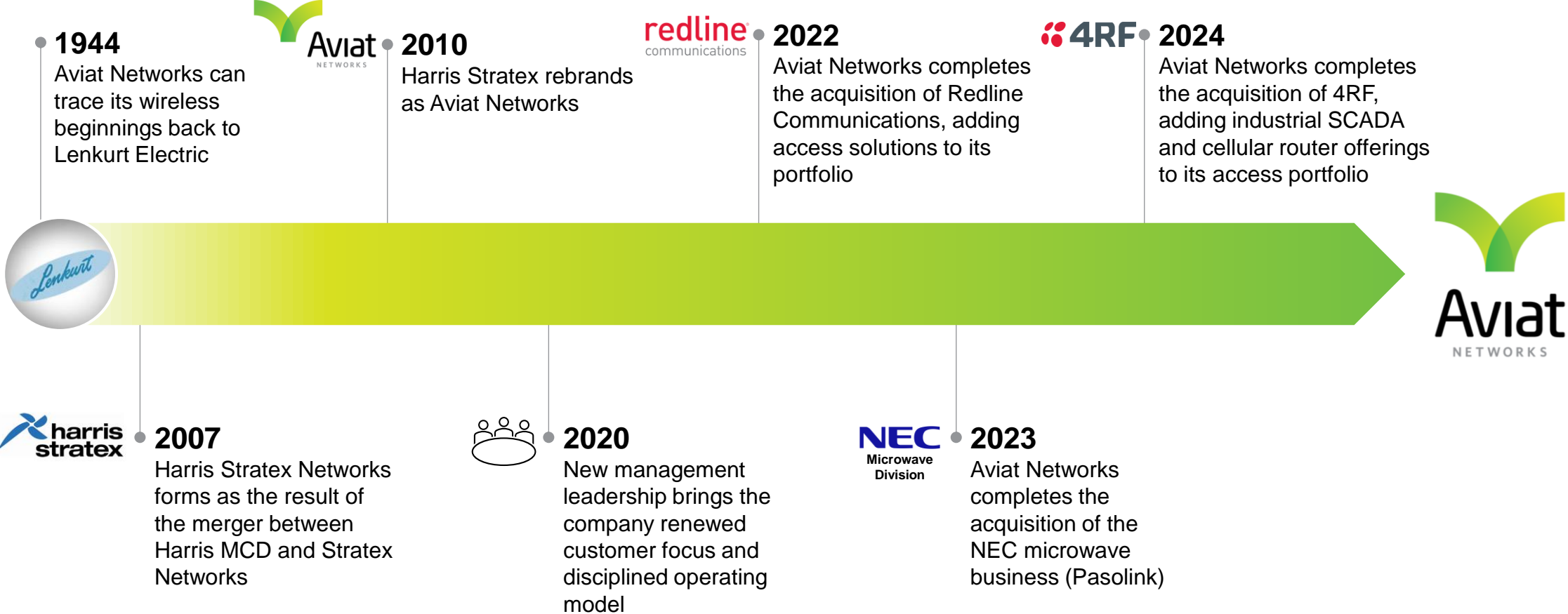

A Long History of Wireless Leadership Invigorated by New Leadership and Consistent Execution

Investment Opportunity

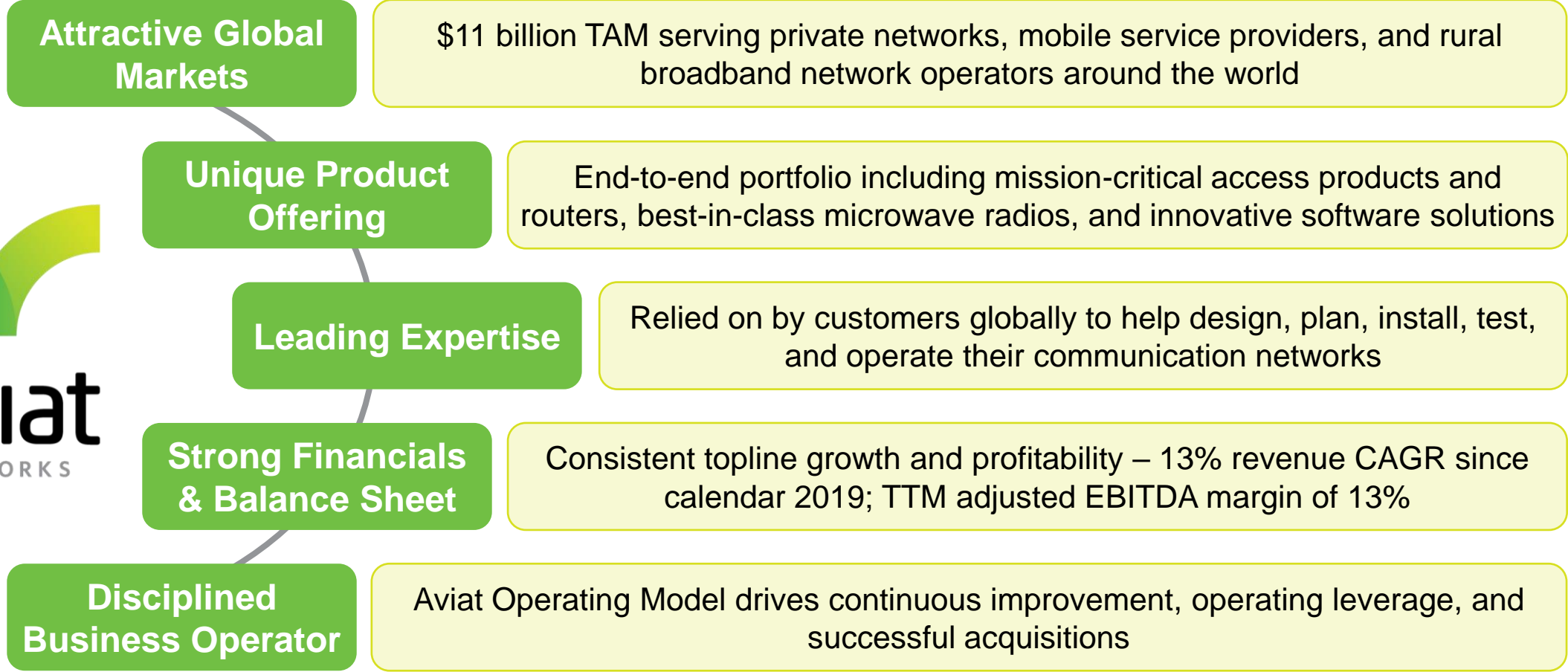

Global Investment in Mission Critical, 5G, and Rural Broadband Networks Underpin Strong and Growing Demand Environment

Why Aviat Wins

	Aviat's Competitive Advantage	vs. Microwave Specialists	vs. Wireless Generalists
Products	<ul style="list-style-type: none"> ✓ Modular radio platform ✓ End-to-end offering of radios, multi-band, routers, access ✓ Better RF performance 	<ul style="list-style-type: none"> • Highly leveraged in chipsets • Difficult to create new product variants quickly • Unable to invest in routing and other products 	<ul style="list-style-type: none"> • Microwave not focus • Less responsive and agile to bringing radio solutions to market
Software & Services	<ul style="list-style-type: none"> ✓ Turnkey services portfolio (design, planning, install) ✓ Software innovations to ease network operations and total cost of ownership (AviatCloud, Assurance software) 	<ul style="list-style-type: none"> • Product focus and lack of software investment • Lack of experience and services make competing in private networks difficult 	<ul style="list-style-type: none"> • Lack focus on dedicated software solutions for transport networks
Supply Chain	<ul style="list-style-type: none"> ✓ Core competence – fast deliveries and disruptive go-to-market like the Aviat Store 	<ul style="list-style-type: none"> • Lack modularity limits supply chain flexibility • Unable to create new business models or react to Aviat innovations 	<ul style="list-style-type: none"> • Microwave supply chain not a priority vs. RAN • Cannot react to Aviat innovations

Aviat Provides More Innovation and Better Value Than Our Competitors

Wireless Transport and Access Markets Overview

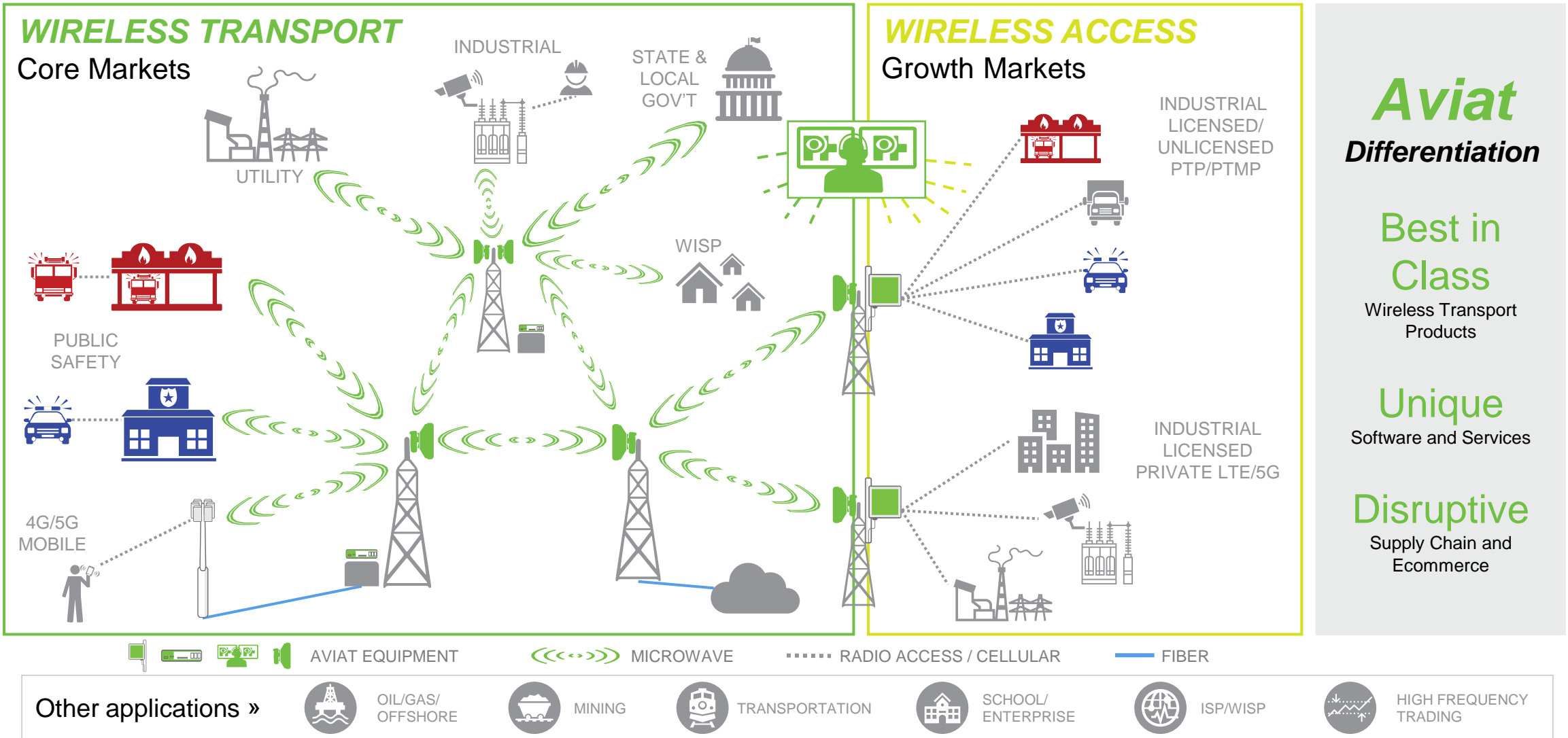

Aviat Differentiation Aligned with Private Networks, 5G and Rural Broadband

Acquisition of 4RF Opens New Wireless Access Segment

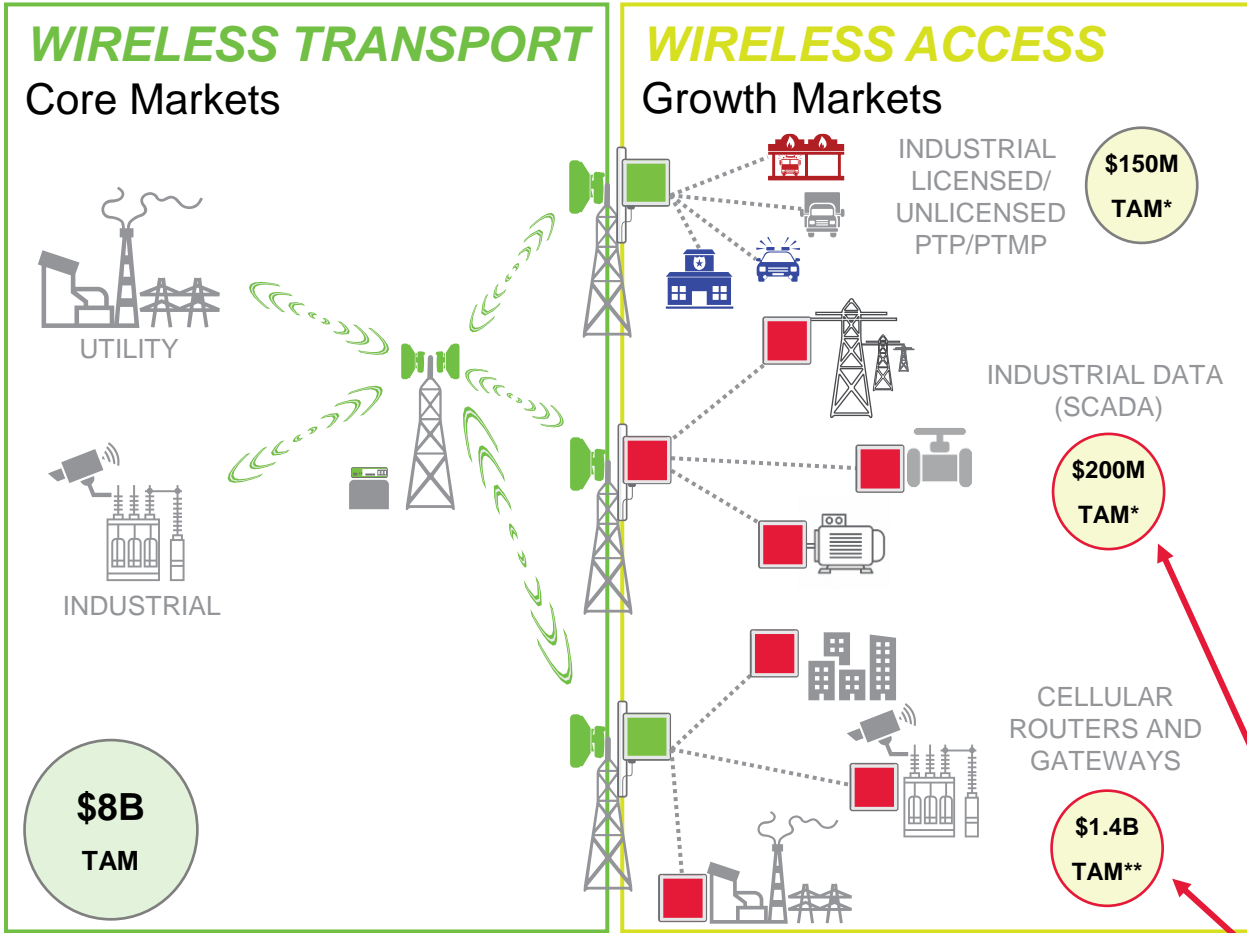

AVIAT EQUIPMENT 4RF EQUIPMENT MICROWAVE RADIO ACCESS

What 4RF Brings to Aviat:

- **Attractive Customer Segment and Increased Private Network Exposure**
 - Sales: ~70% North America, ~85% Utilities
 - Approx. 90% of 4RF and Aviat Networks utility customers are distinct – creates future cross-selling opportunities
- **Market Leading Access Products Designed for High Performance and High Reliability**
 - Private radio and LTE cellular routers for smart grid, distribution automation, metering and renewables, as well as general supervisory control and data acquisition (SCADA) and telemetry applications



Aprisa SR Aprisa SR+ Aprisa XE Aprisa LTE

- **Opens New \$200M Wireless Access Segment (Industrial SCADA)**
- **Opens Segments of the Cellular (LTE/5G) Router Market – Leverages Aviat's Private Networks Presence**

4RF is an Attractive Bolt-On Acquisition That Expands and Strengthens Aviat's Offering in Private Network Industrial Access

Aviat Product Portfolio



Health Assurance (HAS)

Detailed reports on network issues
Reduces downtime



ProVision Plus Network/Element Management

Simplifies network management
Easy trouble shooting with multi-layer visualization



Frequency Assurance (FAS)

Monitors and reports Interference
Protects against WiFi-6E



Split-Mount Systems

iPasolink VR

- 6 to 38GHz freq. band
- Sub-band free ODU options
- Modular and scalable indoor units
- Standard and High-Power Outdoor Units
- No single point of failure options

Markets: Mobile Service Providers, Utilities, Public Safety, Oil & Gas, Mining, Transportation



All-Outdoor Systems

WTM 4000, EX/A, EX/AD

- Single, Dual Channel or Multi-Band
- Full IP/ MPLS Capabilities
- Unique Multi-Band extended distance and vendor agnostic options
- 25GbE connectivity

Markets: Mobile Service Providers, WISPs, Utilities, Public Safety, Oil & Gas, Mining, Transportation

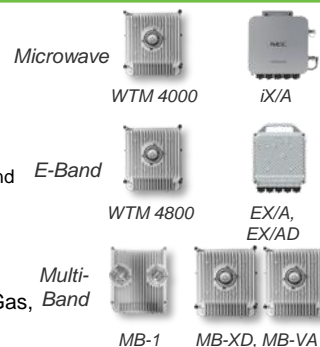

Private LTE/5G

RDL 6000, Aprisa LTE/5G, Aviat Core

- Base station, LTE/5G routers and EPC Core
- Power of a Macro in Small Cell footprint
- Lower power consumption
- Scalable EPC
- Ruggedized, secure cellular routers

Markets: Utilities, Public Safety, Oil & Gas, Mining, Transportation



Trunking Systems

STR 4500, OBC2, 7000iP TRP

- Split Mount, All-Indoor, and All-Outdoor Trunking Systems
- Up to 20 channels with diversity
- 10Gbps connectivity
- Flexible aggregation options

Markets: Mobile Service Providers, Utilities, Public Safety, Oil & Gas, Mining, Transportation



Indoor Radio

IRU600, TRP, Eclipse

- Ultra-High Tx Power, +37dBm
- Compact/expandable antenna branching
- Tough, Durable and Dependable
- Comprehensive native TDM features
- Strong Security (FIPS)

Markets: Utilities, Public Safety, Oil & Gas, Mining, Transportation



Microwave Routers

CTR8000 Series

Wireless Transport



CTR 8780
CTR 8540

Markets: Mobile Service Providers, WISPs, Utilities, Public Safety, Oil & Gas, Mining, Transportation

Industrial Access

Narrowband PTP, PTMP and Nomadic Solutions

- PTP, PTMP licensed and unlicensed
- UHF, VHF, 220MHz - 5.8GHz
- Hardened and secure
- Innovative nomadic, self align offering
- ATEX/Hazloc

Markets: Utilities, Public Safety, Oil & Gas, Mining, Transportation

Wireless Access

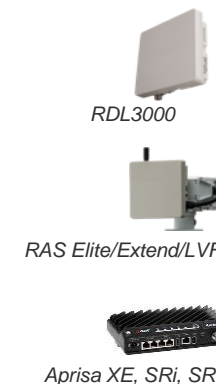

Portfolio Focused on Lowering Total Cost of Ownership

AVIAT NETWORKS

How Aviat Lowers Total Cost of Ownership

1. Reduced Tower Footprint

What: Lower power consumption, faster installation, smaller antennas, reduced tower loading, lower lease costs

How: Fewer boxes, high system gain, Multi-Band

2. Capacity Scalability

What: Less congestion, fewer truck rolls, less hardware

How: Multi-Band, A2C+, on-demand capacity upgrades

3. Integrated Routing

What: Reduced or zero indoor footprint, fewer boxes, simplified operations, lower power consumption

How: All-Outdoor at the edge, CTR/WTM integrated IP/MPLS



4. Spectrum Fee Savings

What: Reduced recurring spectrum fees

How: Moving capacity from Microwave to E-Band and Multi-Band

5. Higher Network Reliability

What: Better performance, increased resilience, fewer outages, faster fault-finding/restoration, lower OPEX

How: High MTBF, High Availability Routing, Aviat Assurance Software (HAS, FAS)

6. Simplified Logistics

What: Easy online design and ordering, fast delivery, Reduced inventory and warehouse costs

How: Aviat Design, Aviat Store, regional stock, on-demand capacity and license upgrades



Microwave is a Crucial Backhaul Technology



Microwave



Fiber

Speed to Deploy	✓	
High Reliability	✓	
Low Latency	✓	
Terrain Flexibility	✓	
Capacity		✓
Cost	Per Link	Per Foot

Microwave is ideally suited for mission-critical private networks, rural broadband, and challenging deployment environments

Wireless transport accounts for 60% of cellular transport links

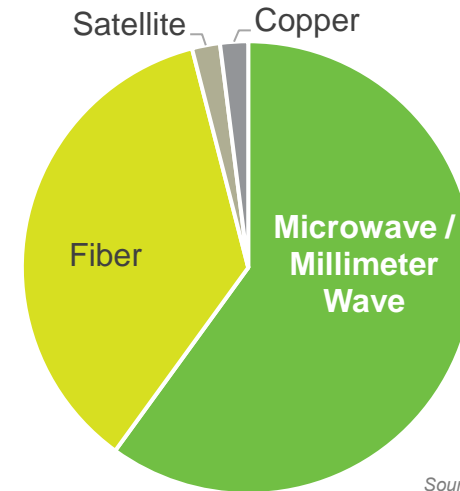

Source: Dell 'Oro; Excludes North East Asia

Service providers rely on microwave in their networks to provide cost-effective and reliable bandwidth

Microwave Backhaul is Essential in Communication Networks Globally

Aviat's Market Opportunities

Private Networks

- Upgrade cycle in public safety, utilities and other private networks driven by increase bandwidth needs
- Private LTE / 5G market to be \$8B by 2027
- Aviat's end-to-end product and services allow for increasing share of wallet capture and competitive advantage

Mobile Networks & 5G

- Early stages of global 5G upgrade cycle; mobile network data traffic expected to grow at 26% CAGR through 2028
- Wireless transport makes up 60% of cellular transport links
- Microwave radio market for global 5G transport market expect to grow at a 39% CAGR through CY2025

Rural Broadband

- Over \$70 billion in U.S. government funding programs to build out rural broadband networks
- Microwave is a compelling solution for operators to lower total cost of ownership and increase speed to deploy
- Aviat's unique e-commerce platform allows for direct to network operator channel

Aviat Networks is Capturing Additional Market Share Because of Its Innovative Portfolio and Focus on Lowest Total Cost of Ownership

Private Network Summary

Growth Drivers

- Growth in Private LTE and Industrial IoT driven by video and modern applications
- States and municipalities upgrading their public safety communications
 - State and local budgets remain healthy; growing public safety funding
- American Rescue Plan Act (ARPA) funding of \$350 billion for U.S. States' water, sewer, public safety, and broadband infrastructure
- Vendor outsourcing and declining microwave expertise creates share of wallet opportunities

Segments Addressed

Public Safety and Security



Oil & Gas

Water

Electric Utilities



National / Regional Government

Enterprise



Aviat's Leadership

- Mission critical product differentiation
 - Highest powered radios
 - Ruggedized access products
 - IP/MPLS integration
 - Software innovations to simplify network management (PV+, HAS, FAS)
- Strong state relationships and global partners
- Differentiated services offerings
 - Network design and testing
 - Install
 - Support
 - Managed services (incl. NOC)

Aviat Offers a Compelling Value Proposition to Private Network Operators

Mobile Networks & 5G Market Summary

- Mobile service provider market driven by increasing bandwidth demand in 4G and 5G networks
 - Data from global networks is anticipated to grow rapidly (26% CAGR) through 2028, driven by 5G adoption and expanding 4G networks
- Aviat's product portfolio enables operators to increase their network capacity while lowering total cost of ownership (TCO)
 - **Single-box multi-band** lowers tower leasing costs while increase capacity
 - **Vendor-agnostic multi-band** allows operators to utilize existing radios and layer on Aviat's solution, lowering the barrier to entry for Aviat into a network
 - **Multi-band XD** enables longer distances between links which helps to minimize total network capex
 - **Highest capacity** radio available on the market (20 Gbps)
- Aviat's multi-band is up to \$10,000/link lower TCO vs competitive multi-band offerings
 - **Superior** solution → **Less** hardware → **Lowest** TCO

Global 5G Wireless Transport Market

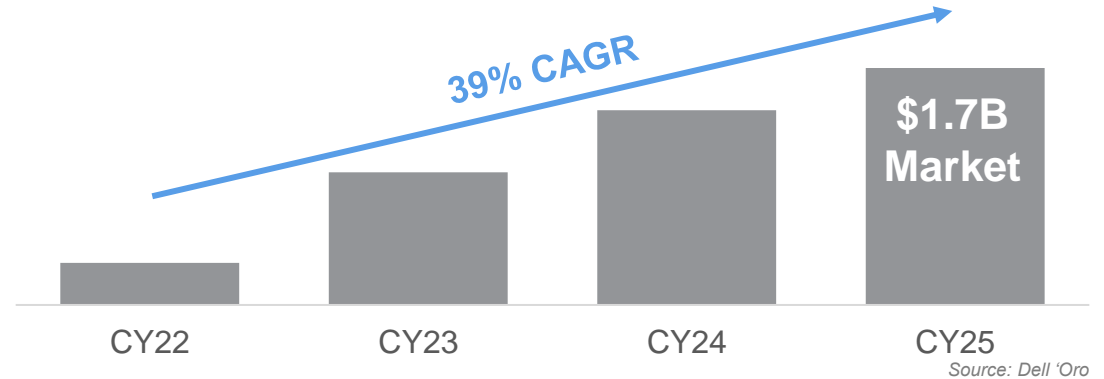

Global Mobile Network Data Traffic

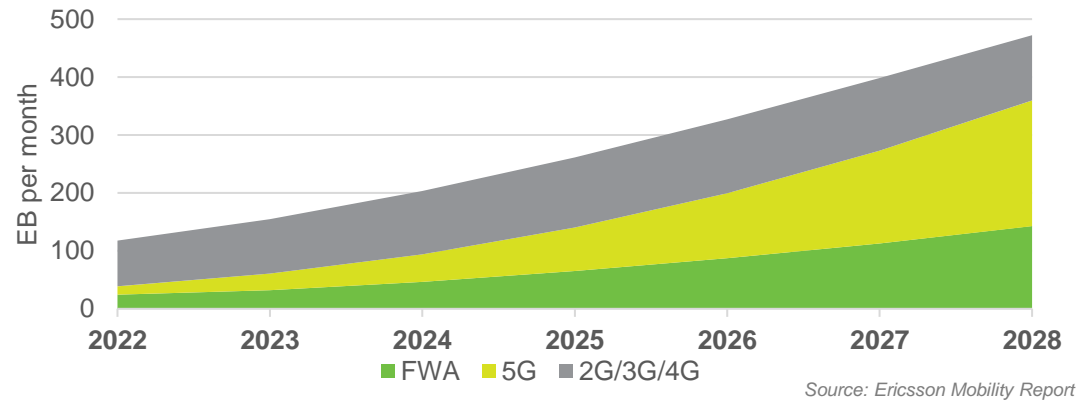

Demand for Wireless Transport Driven by Increasing Data Consumption

Rural Broadband Summary

Aviat E-Commerce Platform Leads Rural Broadband

Aviat is uniquely suited to serve WISPs through its Aviat Store and AviatCloud applications like Design (network planning and product recommendation) and automated radio and license applications

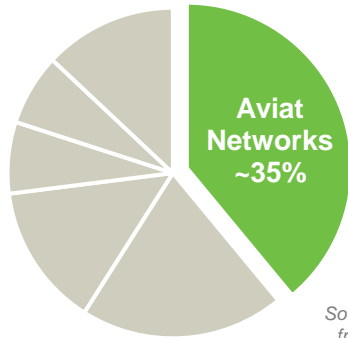

Source: PCN data from Comsearch

Leading wireless transport share of demand for North American ISPs

Wireless Transport is the Solution

Wireless transport is ideal for rural communities and is lower cost, more reliable, and faster to deploy than fiber

Growing number of Fixed Wireless Access (FWA) deployments favors wireless backhaul

Estimate the USA rural broadband segment to be a ~\$420M TAM in 2024

Over \$70B in Available Funding

\$1.5 Billion	CAF II
\$20 Billion	Rural Digital Opportunity Fund (RDOF)
\$9 Billion	5G Fund for Rural America
\$42.5 Billion	Broadband Equity, Access, and Deployment (BEAD) Program
\$635 Million	USDA Reconnect Program

Large Investments in Broadband Infrastructure Creates Opportunities for Wireless Transport

Aviat Operating Model Framework

Excellence in

Customer Focus



Innovation



Talent



Supply Chain



Our Actions

We listen during the commercial and sales process to understand our customers' needs and use our combined talents, skill and capabilities to create solutions that exceed expectations.

We deliver innovative, high-quality solutions that meet key customer segment needs. Voice of customer informs investment decisions. Release to market within budget, timeframe and scope.

We drive a performance culture and invest in our talent management programs to support evolving strategic business needs and implement organizational structures to facilitate results.

We achieve a competitive advantage by delivering quality products with best-in-class lead-times.

Our Processes

- Standard global VOC process
- Sales Goal planning
- eCommerce platform
- AviatCare customer service and support

- Aviat Operating System for software
- New Product Introduction (NPI) process
- Portfolio management
- Agile development methodology

- Performance Management Process
- Career Framework
- Talent Management Review
- Employee Ownership Program

- S&OP Planning
- Next day delivery e-commerce
- Order to Cash process
- Strategic sourcing to meet customer objectives globally

Continuous Improvement | We Strive Everyday...

To improve, innovate and drive cost efficiency to achieve higher performance and to promote our continuous improvement culture

Aviat Operating Model Supports Growth-Centric Culture by Leveraging Continuous Improvement and Driving Competitive Excellence

Third Quarter Fiscal 2024 Financial Highlights and Historical Performance

Third Quarter Fiscal 2024 Highlights

Revenue & Non-GAAP Gross Margin

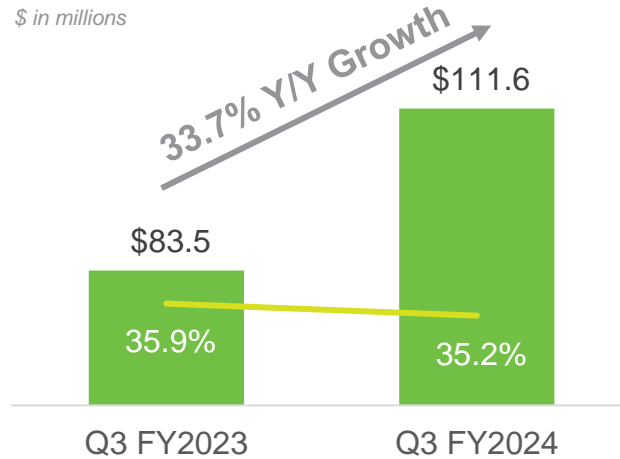

Adjusted EBITDA & Adj. EBITDA Margin

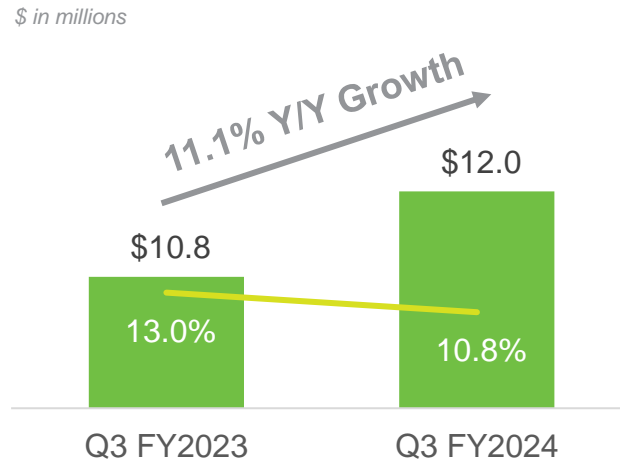

- Revenue of \$111.6 million, up 33.7% compared to the same period last year
 - Core Aviat revenue growth of 7%
- Non-GAAP gross margin of 35.2%
- Non-GAAP operating income of \$10.8 million, up 16.2% year-over-year
- Adjusted EBITDA of \$12.0 million, up 11.1% compared to the same period last year
- Non-GAAP earnings per share of \$0.73
- Continued profit growth from disciplined cost management and topline execution

Laser Focused on Increasing Revenue, Capturing Aviat's Differentiation, Driving Costs Out, and Increasing Overall Shareholder Value

Third Quarter Fiscal 2024 Balance Sheet Highlights

(\$'s in millions, except for DSO, DPO and Turns)	Q3 FY22 Actual	Q4 FY22 Actual	Q1 FY23 Actual	Q2 FY23 Actual	Q3 FY23 Actual	Q4 FY23 Actual	Q1 FY24 Actual	Q2 FY24 Actual	Q3 FY24 Actual
Cash Equivalents and Marketable Securities	\$33.8	\$47.8	\$22.9	\$21.4	\$22.5	\$22.2	\$35.5	\$45.9	\$59.2
Third-Party Debt	\$0.0	\$0.0	\$0.0	\$0.0	(\$6.2)	\$0.0	\$0.0	(\$49.5)	(\$48.9)
Net Cash and Marketable Securities	\$33.8	\$47.8	\$22.9	\$21.4	\$16.3	\$22.2	\$35.5	(\$3.6)	\$10.2
Accounts Receivable	\$76.2	\$73.2	\$72.5	\$91.4	\$88.5	\$101.7	\$94.5	\$149.9	\$138.4
Unbilled Receivables	\$45.7	\$45.9	\$50.4	\$53.6	\$63.3	\$58.6	\$61.0	\$77.2	\$74.7
Advance Payments and Unearned Revenue	(\$45.7)	(\$42.7)	(\$43.3)	(\$46.7)	(\$48.0)	(\$51.7)	(\$53.7)	(\$63.0)	(\$49.8)
DSO's	89	88	82	82	98	95	102	117	118
DSO's net of Unbilled/Unearned	88	90	87	89	110	106	109	127	133
Accounts Payable	(\$40.6)	(\$42.4)	(\$48.2)	(\$59.8)	(\$61.7)	(\$60.1)	(\$61.8)	(\$67.4)	(\$64.6)
DPO's	81	76	80	84	103	95	100	101	80
Inventory	\$30.5	\$27.2	\$35.0	\$37.1	\$40.9	\$33.1	\$30.7	\$66.8	\$56.8
Turns	6.5	6.9	6.7	6.5	5.5	6.3	7.0	4.8	4.9

Note: Pasolink acquisition closed on November 30, 2023. Q2 FY24 balance sheet metrics begin reflecting the impact of the Pasolink acquisition.

Asset / (Liability)

- Cash and marketable securities increased by \$13.3 million in the quarter
- Net cash position of \$10.2 million
- Improved DSOs and inventory turns excluding the impact from the Pasolink acquisition
- Preliminary purchase price allocation from the Pasolink acquisition:
 - Accounts receivable, net: \$51.8M
 - Inventories: \$34.2M
 - Advanced payments and unearned revenue: \$3.2M
 - Accounts payable: \$13.2M
 - Total net assets acquired: \$76.9M

Strong Balance Sheet; Consistent Performance Drives Cash Generation

Rolling Trailing Twelve Months Historical Performance

\$ in millions

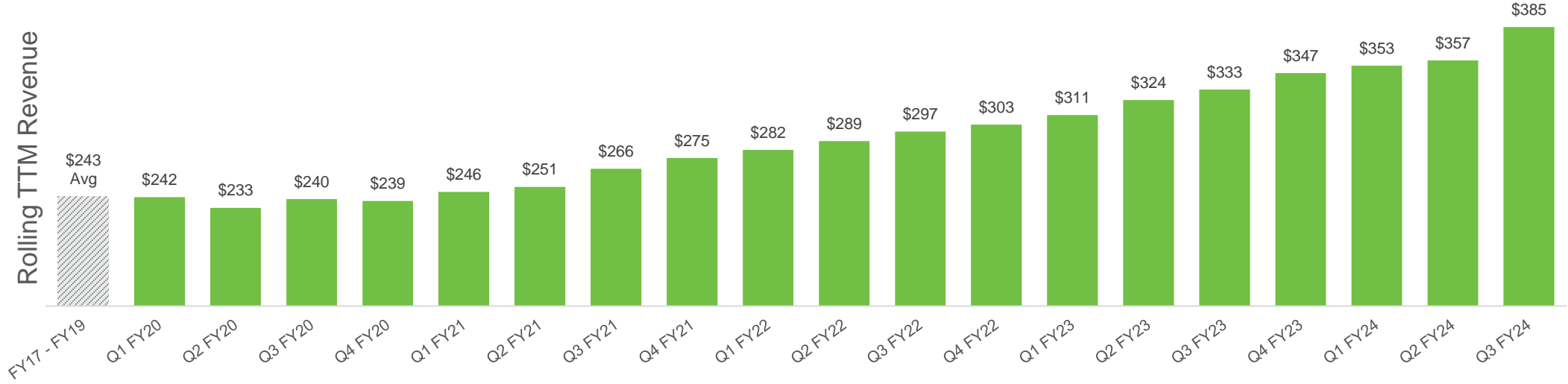

\$ in millions

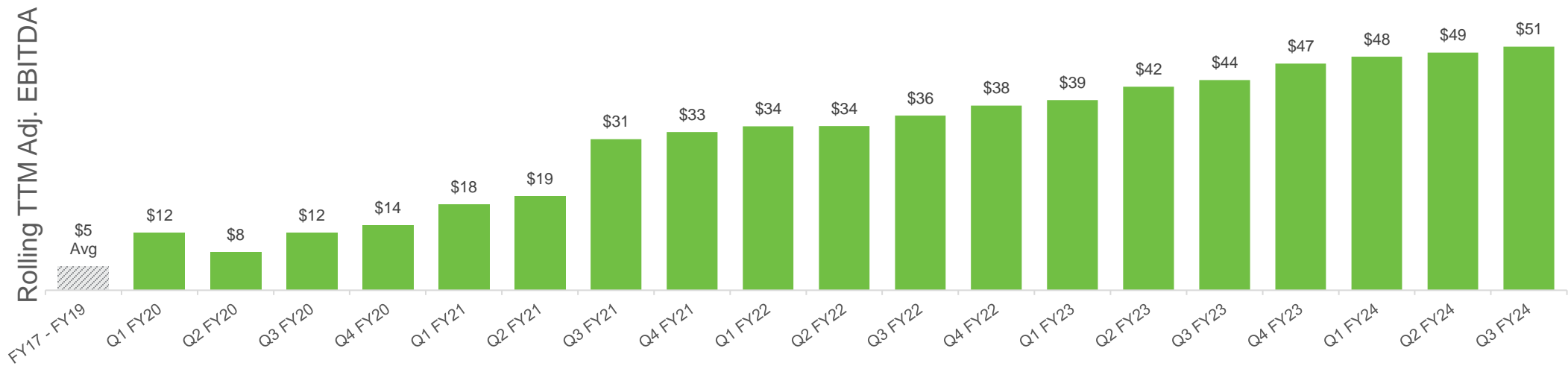

Cash Benefit of Historical Net Operating Losses (NOLs)

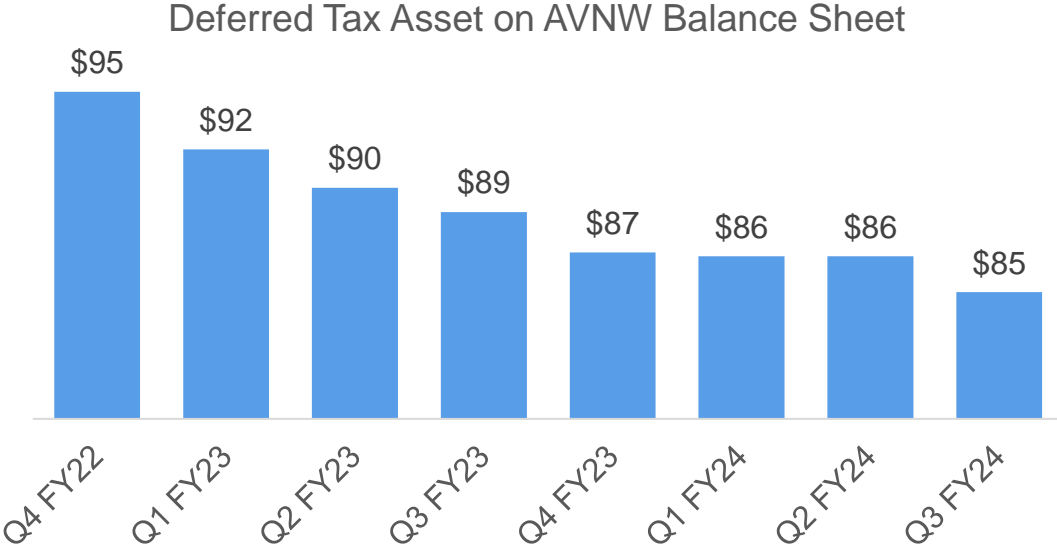
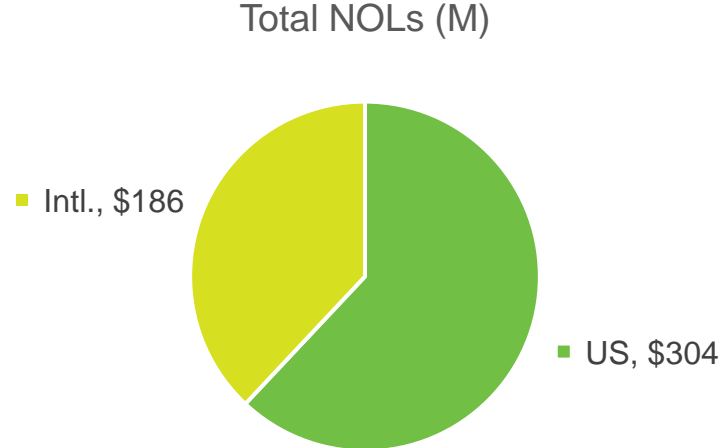

- \$490 million of gross NOLs
- NOL's reduce Aviat's statutory federal and state blended tax rate of ~25% to an effective cash tax rate of ~5%
 - This saved Aviat \$5.9 million in cash taxes in FY22 and \$14.1 million in cash taxes in FY23

- Improved financial performance and outlook for Aviat resulted in a full release of the valuation allowance against U.S. NOLs in Q3 of fiscal 2021
 - A one-time benefit of \$92 million was recognized in Net Income and Deferred Tax Assets

Cash Tax Savings Will Continue for the Foreseeable Future at Levels Commensurate with our Earnings Before Tax Performance

GAAP to Non-GAAP Reconciliation

RECONCILIATIONS OF NON-GAAP FINANCIAL MEASURES ⁽¹⁾

Condensed Consolidated Statements of Operations

(Unaudited)

	Three Months Ended				Nine Months Ended			
	29-Mar-24	% of Revenue	31-Mar-23	% of Revenue	29-Mar-24	% of Revenue	31-Mar-23	% of Revenue
(In thousands, except percentages and per share amounts)								
GAAP gross margin	\$36,534	32.7%	\$29,833	35.7%	\$105,216	35.8%	\$91,507	35.8%
Share-based compensation	126		125		310		463	
Merger and acquisition related expense	2,650		6		2,759		6	
Non-GAAP gross margin	39,310	35.2%	29,964	35.9%	108,285	36.8%	91,976	36.0%
GAAP research and development expenses	\$10,623	9.5%	\$6,518	7.8%	\$25,441	8.6%	\$18,652	7.3%
Share-based compensation	(155)		(113)		(452)		(385)	
Non-GAAP research and development expenses	10,468	9.4%	6,405	7.7%	24,989	8.5%	18,267	7.2%
GAAP selling and administrative expenses	\$21,300	19.1%	\$15,842	19.0%	\$61,979	21.1%	\$49,913	19.5%
Share-based compensation	(1,605)		(1,400)		(4,783)		(4,287)	
Merger and acquisition related expense	(1,657)		(179)		(8,051)		(1,799)	
Non-GAAP selling and administrative expenses	18,038	16.2%	14,263	17.1%	49,145	16.7%	43,827	17.2%
GAAP operating income	\$5,028	4.5%	\$7,496	9.0%	\$15,569	5.3%	\$20,087	7.9%
Share-based compensation	1,886		1,638		5,545		5,135	
Merger and acquisition related expense	4,307		185		10,810		1,805	
Restructuring (recovery) charges	(417)		(23)		2,227		2,855	
Non-GAAP operating income	10,804	9.7%	9,296	11.1%	34,151	11.6%	29,882	11.7%
GAAP income tax provision	\$619	0.6%	\$2,179	2.6%	\$3,607	1.2%	\$9,148	3.6%
Adjustment to reflect pro forma tax rate	(119)		(1,879)		(2,507)		(8,248)	
Non-GAAP income tax provision	500	0.4%	300	0.4%	1,100	0.4%	900	0.4%

	Three Months Ended				Nine Months Ended			
	29-Mar-24	% of Revenue	31-Mar-23	% of Revenue	29-Mar-24	% of Revenue	31-Mar-23	% of Revenue
(In thousands, except percentages and per share amounts)								
GAAP net income	\$3,418	3.1%	\$4,889	5.9%	\$10,313	3.5%	\$8,189	3.2%
Share-based compensation	1,886		1,638		5,545		5,135	
Merger and acquisition related expense	4,307		185		10,810		1,805	
Restructuring (recovery) charges	(417)		(23)		2,227		2,855	
Other expense, net	63		306		228		2,540	
Adjustment to reflect pro forma tax rate	119		1,879		2,507		8,248	
Non-GAAP net income	\$9,376	8.4%	\$8,874	10.6%	\$31,630	10.8%	\$28,772	11.3%
Diluted net income per share:								
GAAP	\$0.27		\$0.41		\$0.84		\$0.69	
Non-GAAP	\$0.73		\$0.75		\$2.57		\$2.43	
Shares used in computing net income per share								
GAAP	12,779		11,884		12,325		11,829	
Non-GAAP	12,779		11,884		12,325		11,829	
Adjusted EBITDA:								
GAAP net income	\$3,418	3.1%	\$4,889	5.9%	\$10,313	3.5%	\$8,189	3.2%
Depreciation and amortization of property, plant and equipment and intangible assets	1,244		1,552		3,728		4,565	
Interest expense, net	928		122		1,421		210	
Other expense, net	63		306		228		2,540	
Share-based compensation	1,886		1,638		5,545		5,135	
Merger and acquisition related expense	4,307		185		10,810		1,805	
Restructuring (recovery) charges	(417)		(23)		2,227		2,855	
Provision for income taxes	619		2,179		3,607		9,148	
Adjusted EBITDA	\$12,048	10.8%	\$10,848	13.0%	\$37,879	12.9%	\$34,447	13.5%

(1) The adjustments above reconcile our GAAP financial results to the non-GAAP financial measures used by us. Our non-GAAP net income excluded share-based compensation, and other non-recurring charges (recovery). Adjusted EBITDA was determined by excluding depreciation and amortization on property, plant and equipment, interest, provision for or benefit from income taxes, and non-GAAP pre-tax adjustments, as set forth above, from GAAP net income. We believe that the presentation of these non-GAAP items provides meaningful supplemental information to investors, when viewed in conjunction with, and not in lieu of, our GAAP results. However, the non-GAAP financial measures have not been prepared under a comprehensive set of accounting rules or principles. Non-GAAP information should not be considered in isolation from, or as a substitute for, information prepared in accordance with GAAP. Moreover, there are material limitations associated with the use of non-GAAP financial measures.



Aviat
NETWORKS



WWW.AVIATNETWORKS.COM